

STAINLESS STEEL Y-STRAINER



FEATURES:

- *Applications for Hydraulic, Chemical, Steam, Oil/Gas, Oxygen, Vacuum
- *Investment Cast Stainless Steel Body & Cover
- *Bolted Cover, Y Type
- *Stainless Steel Screen.
- *With Drain Plug.
- *EN 10204-3.1 Certificate Available

Standard:

- *Basic Design to API 603; ASME B16.34
- *Class 150: Flange dimension according to ANSI B16.5 PN16: Flange dimension to DIN 2633 PN 16
- *Class 150: Face to face meets to ANSI B16.10 PN16 Face to face meets to DIN 3202 F1
- *Inspection & testing according to API 598

SPECIFICATIONS:

- *Flow Bore: full port.
- *Rating : ANSI Class 150/300; JIS10K/20K; DIN PN16/25/40
- *Temperature: -20°F ~ 400°F
- *Materials: CF8
- *Size range: 1/2" ~ 6"
- *Screen size: 1/2" ~ 1" : 1.5 mm
1-1/2" ~ 6" : 2 mm

No	Part Name	Material
1	Body	CF8
2	Screen	SS304
3	Gasket	PTFE
4	Cover	CF8
5	Drain Plug	SS 304
6	Bolt	SS 304

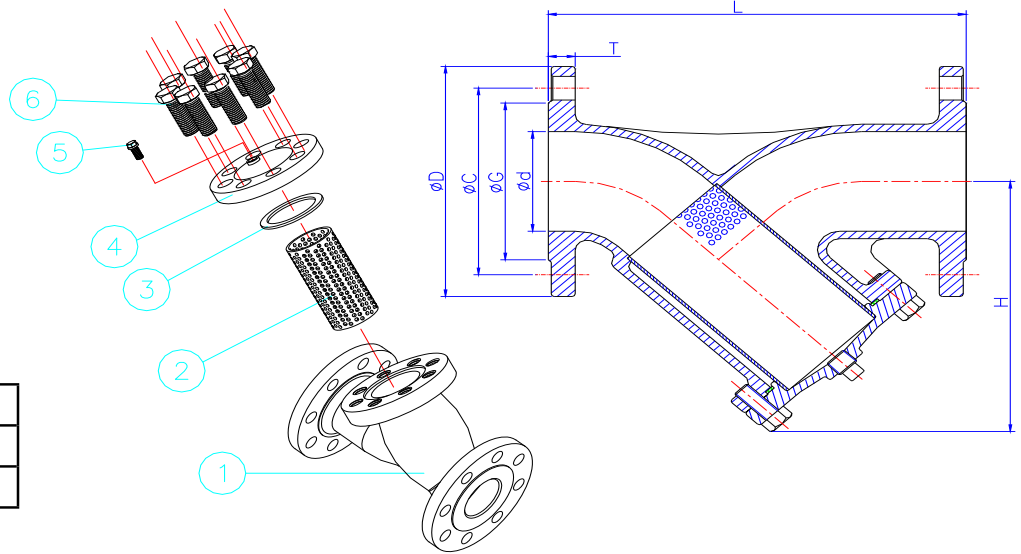

Screen Specification

Size	Perforation
1/2"-1-1/4"	1.5mm
1-1/2"-6"	2.0mm

JIS 10K DIMENSIONS

Size	d	L	H	D	C	G	T
				10K	10K	10K	10K
1/2	15	120	85	95	70	51	12
3/4	20	140	87	100	75	56	14
1	25	150	114	125	90	67	14
1-1/4	32	180	115				
1-1/2	40	190	135	140	105	81	16
2	50	210	155	155	120	96	16
2-1/2	65	250	189	175	140	116	18
3	80	280	200	185	150	126	18
4	100	340	232	210	175	151	18
5	125	380	274	250	210	182	20
6	150	420	326	280	240	212	22